

ACCESS COMPLIANCE ASSESSMENT REPORT

ST MARY ST JOSEPH CATHOLIC PRIMARY SCHOOL
280 FITZGERALD AVENUE MAROUBRA NSW 2035

DATE ► 15/05/2020

REPORT NO. ► PROJECT 9549 - REV 3.0

PREPARED FOR ► JDH ARCHITECTS PTY LTD

PREPARED BY ► AE&D



AEDGROUP

Innovation & expertise in building regulations

**CONTENTS**

| | |
|---|-----------|
| EXECUTIVE SUMMARY & RECOMMENDATIONS | 3 |
| 1.0 Introduction | 6 |
| 1.1 Basis of Report..... | 6 |
| 1.2 Limitations of the Report | 6 |
| 1.3 BCA Assessment Data | 7 |
| 2.0 BCA-Technical Review Assessment and Commentary | 8 |
| 3.0 Conclusion | 27 |

REVISION STATUS

| REPORT/REV | DATE | STATUS | WRITTEN | CHECKED |
|----------------|----------|--|---------|---------|
| 9549 – REV 1.0 | 04/09/19 | Draft Report for client comment / submission | CM | TJ |
| 9549 – REV 2.0 | 01/05/20 | Report for client comment /submission | CM | TJ |
| 9549 – REV 3.0 | 15/05/20 | Final Issue to Client | CM | TJ |

COMMERCIAL IN CONFIDENCE

This document contains confidential material that is intended solely for the client commissioning AED to prepare this report. The client, project team and all regulatory authorities shall exercise precautionary measures to ensure that the information contained herein is not to be accessed by any third party. AED will take no responsibility for the use of any information contained within this report by any third party, unless AED's permission is requested and provided in writing.



EXECUTIVE SUMMARY & RECOMMENDATIONS

This report provides an accessibility design assessment for Development Application Phase documentation of the proposed demolition of existing buildings A & B, associated sunshade, covered walkways & COLA. Relocation of ASPECT demountable classroom building, Refurbishment of Blocks D & E into 4 GLA's with dividers and a new art's & Aspect room. Construction of a new Staff, Administration, Library & GLA's (First floor) and construction of a new basketball court and soccer field & landscape areas located at 280 Fitzgerald Avenue Maroubra.

The purpose of this report is to identify the compliance status with the Refurbishment of Blocks D & E into 4 GLA's with dividers and a new art's & Aspect room. Construction of a new Staff, Administration, Library & GLA's (First floor) and construction of a new basketball court and soccer field & landscape areas with the following:

- Relevant accessibility related Deemed-to-Satisfy (DtS) requirements of the Building Code of Australia (BCA) 2019, as are contained within Part D3 and Clause E3.6 and F2.4 of the Code.

A detailed "Technical Review and Commentary" is provided at [Part 2.0](#) and [Part 3.0](#) of this Report, which includes all appropriate technical assessment results and commentary and concludes that, whilst some compliance departures do exist in the current design, such can be remedied in all instances to achieve compliance with the BCA.

| BCA Clause | Deemed-to-Satisfy Provision to be addressed |
|--|---|
| D3.1 General building access requirements | <p>Discussions held with the Architect confirmed the removal of Stair 2 from Zone B Ground floor plan and therefore it has not been considered as part of this access review.</p> <p>In addition to the above, discussions held with the Architect confirmed the cabinetry (sinks) to the Art/Aspect, GLA 4, 5 & 6 were currently under review to achieve compliance with the circulation spaces for doorways and are yet to be confirmed. Compliance to be determined at CC stage.</p> <p>The following requires to be addressed on amended plans;</p> <p><u>Zone A & B – Doorways</u></p> <ul style="list-style-type: none"> • New single doorways are notated to be recessed within 460mm thick walls. The Australian Standard is silent on the wall thickness with a swinging door located within. Discussions held with the Architect confirmed these doorways are under revision to ensure compliance can be achieved. Architect to confirm prior to CC stage. AED suggests that the wall opening be increased to account for the latch side clearances of where required by Clause 13.3 of 660mm (worst case scenario) of AS1428.1-2009. Alternatively, where the DtS provisions cannot be achieved discussions should be held with a suitably qualified access consultant to determine if a performance-based solution is applicable. <p><u>Zone A – Ground floor</u></p> <ul style="list-style-type: none"> • Doorway to office (adjoining student office & sick bay) maintains a latch side clearance of circa 150mm where 510mm is required when a frontal approach is taken, and the doorway opens away from the user in accordance with Clause 13.3 of AS1428.1-2009. Refer to figure 31(d) below. |

BCA Clause

Deemed-to-Satisfy Provision to be addressed

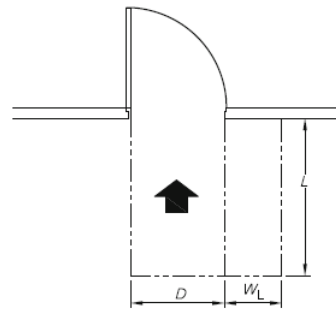

| Dimension D | Dimension L | Dimension W_H | Dimension W_L |
|------------------|------------------|--------------------|--------------------|
| 850 | 1450 | 0 | 510 |
| 900 | 1450 | 0 | 510 |
| 950 | 1450 | 0 | 510 |
| 1000 | 1450 | 0 | 510 |

(d) Front approach,
door opens away from user

Zone B – Ground floor

- Plans identifies doorways throughout the ground floor maintaining less than 850mm openings (circa 705mm). A doorway shall be 850mm when measured from the face of the opened door to the doorstop. Refer to figure 30 below for clear openings of doorways. All doors are to be reviewed to ensure 850mm opening exists.

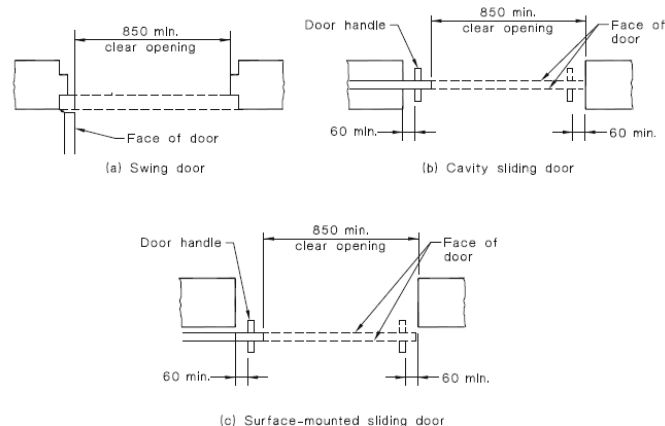

(a) Swing door
(b) Cavity sliding door
(c) Surface-mounted sliding door
DIMENSIONS IN MILLIMETRES
FIGURE 30 CLEAR OPENING OF DOORWAYS

- Bi-fold doorways to ART room are not an acceptable doorway under AS1428.1-2009 and it is suggested that these doors are reviewed prior to CC stage.

D3.2 – Access to Buildings

Discussions held with the Architect confirmed an accessway is to be provided from Fitzgerald Avenue along the eastern side of Zone B Building and will link up to the hall and the new concrete pathway, therefore connecting all buildings onsite. Additional details to be provided at CC stage.

The following requires to be addressed on amended plans;

Access to buildings

- Site inspection carried out on 3rd September 2019 identified four (4) access points at the lot boundaries. Plans only identify one point of entry to be accessible where two (2) accessways are to be provided in accordance with D3.2. *AED notes that the secondary access will be provided from the allotment boundary on Fitzgerald*

| BCA Clause | Deemed-to-Satisfy Provision to be addressed |
|------------|---|
|------------|---|

Avenue, however the existing concrete path located on Council's land will not achieve compliance with the requirements of AS1428.1-2009. This matter should be raised with Council have the path replaced/realigned.

- Plans indicate an accessway to Zone B building via an internal lift of Zone A building. AED notes that an accessway has been provided, however in the event that access via the lift cannot be accessed then a accessway to Zone B building is not attainable. Client to provide a written statement confirming that access to the lift is to be provided at all times when the buildings are in use. This statement should form part of the building Plan of Management to avoid any future conflicts.
- Walkway connecting buildings from Zone A to Zone B do not identify a kerb or kerb rail and handrail or a wall not less than 450mm in height to both sides of where one of these options are required in accordance with Clause 10.2 of AS1428.1-2009.

Zone B – Ground floor

Double doors

- Plans notate double doors (existing and proposed) with a single leaf door maintain a clear opening of 850mm (circa 635mm – worst case scenario). Double doors on a continuous accessible path of travel must maintain one leaf (active leaf) width of 850mm in accordance with Clause 13.2 of AS1428.1-2009. Refer to figure 30 below for clear openings of doorways.

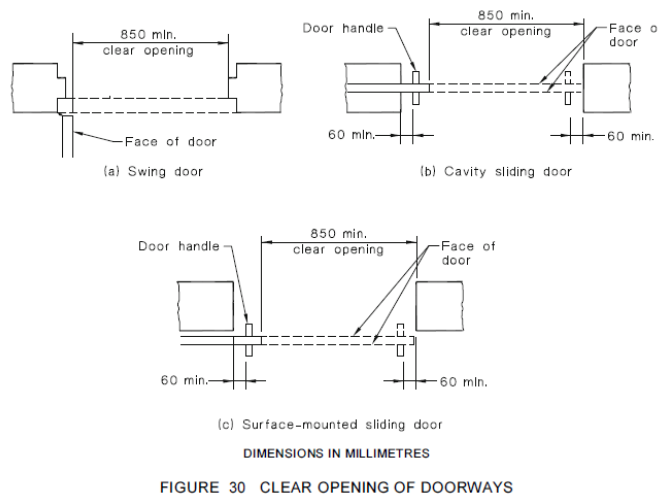

| | |
|------|--|
| F2.4 | The following requires to be addressed on amended plans; |
|------|--|

| | |
|--|---|
| <p>Accessible Facilities</p> <p>Sanitary</p> | <p><u>Zone A – Ground floor</u></p> <ul style="list-style-type: none"> At a bank of toilets of toilets where there is one or more toilets in addition to an <i>accessible unisex sanitary compartment</i> at that bank of toilets, a <i>sanitary compartment</i> suitable for a person with an ambulant disability in accordance with AS 1428.1 must be provided for use by males and females. Zone A identifies two toilets to be ambulant, however grabrails have not been identified where required by Clause 16 of AS1428.1-2009. Details to be confirmed at CC stage. |
|--|---|

1.0 INTRODUCTION

This report provides an accessibility design assessment for Development Application Phase documentation of the proposed demolition of existing buildings A & B, associated sunshade, covered walkways & COLA. Relocation of ASPECT demountable classroom building, Refurbishment of Blocks D & E into 4 GLA's with dividers and a new art's & Aspect room. Construction of a new Staff, Administration, Library & GLA's (First floor) and construction of a new basketball court and soccer field & landscape areas located at 280 Fitzgerald Avenue Maroubra.

The subject development will comprise the construction of a refurbishment of blocks D & E into 8 GLA's and a library with renovation of the existing student toilet facilities.

The purpose of this report is to identify the compliance status of the design with the following:

- Relevant accessibility related Deemed-to-Satisfy (DtS) requirements of the Building Code of Australia (BCA) 2019, as are contained within Part D3 and Clause E3.6 and F2.4 of the Code.

1.1 Basis of Report

This assessment is based upon:

1. Architectural plans prepared by JDH Architects PTY LTD as follows:

| | | |
|--------|---------------------------------------|----------------|
| DA-001 | COVER PAGE | 1:500 |
| DA-002 | DEMOLITION SITE PLAN | 1:400 |
| DA-003 | PROPOSED SITE & ANALYSIS PLAN | 1:400 |
| DA-101 | ZONE A - DEMOLITION GROUND FLOOR PLAN | 1:100 |
| DA-102 | ZONE B - DEMOLITION GROUND FLOOR PLAN | 1:100 |
| DA-103 | ZONE A - DEMOLITION ROOF PLAN | 1:100 |
| DA-104 | ZONE B - DEMOLITION ROOF PLAN | 1:100 |
| DA-111 | ZONE A - PROPOSED GROUND FLOOR PLAN | 1:100 |
| DA-112 | ZONE A - PROPOSED FIRST FLOOR PLAN | 1:100 |
| DA-113 | ZONE A - PROPOSED ROOF PLAN | 1:100 |
| DA-114 | ZONE B - PROPOSED GROUND FLOOR PLAN | 1:100 |
| DA-115 | ZONE B - PROPOSED ROOF PLAN | 1:100 |
| DA-501 | ZONE A - NORTH & SOUTH ELEVATIONS | 1:100, 1:0.... |
| DA-502 | ZONE A - EAST & WEST ELEVATIONS | 1:100, 1:0.... |
| DA-503 | ZONE B - NORTH & SOUTH ELEVATIONS | 1:100 |
| DA-504 | ZONE B - EAST & WEST ELEVATIONS | 1:100 |

2. Site inspection carried out on 3 September 2019.
3. The Building Code of Australia (BCA) 2019 prepared by the Australian Building Codes Board.
4. The Guide to the BCA 2019, prepared by the Australian Building Codes Board.
5. The Disability (Access to Premises – Building) Standards 2010.
6. Australian Standards AS1428.1-2009 - Design for Access and Mobility – Part 1: General requirements for access - New building work.
7. Australian Standards AS1428.4.1-2009 - Design for Access and Mobility – Part 4.1: Means to assist the orientation of people with vision impairment – Tactile ground surface indicators.

1.2 Limitations of the Report

This report does not assess / include the following:

- Review of Construction Certificate (CC) documentation. This review covers early design concepts and additional detailed design assessments are required for CC phase.
- Any parts of the BCA not directly referenced in this report.
- Review of fitouts associated with the retail / commercial spaces.
- Standards not directly referenced in this report.
- Disability Discrimination Act 1992 (*DDA focuses on results and does not offer prescriptive compliance options*).
- Work Health & Safety considerations.
- Work Cover Authority requirements.
- Local planning policies and/or guidelines, other than those identified.
- This report is not a Part 4A compliance certificate under the Environmental Planning & Assessment Act 1979 or Regulation 2000.
- Does not provide concessions, alternative solutions or exemptions from the requirements of the BCA, other than any directly identified in the Executive Summary of this report.

1.3 BCA Assessment Data

Our understanding of the Building Code of Australia 2019 classification(s) in relation to the subject building is as follows (to be confirmed by the BCA Consultant):

| | | |
|-----------------------------|----------|-------------------|
| BCA Building Classification | Class 5 | Office |
| | Class 9b | Assembly Building |

A3.3 Multiple Classification

Where parts have different purposes if not more than 10% of the floor area of a storey, being the minor use, is used for a purpose which is a different classification, the classification applying to the major use may apply to the whole storey.

A1.7 Language

A reference to a building in the BCA is a reference to an entire building or part of a building, as the case requires.

2.0 BCA-TECHNICAL REVIEW ASSESSMENT AND COMMENTARY

The following table details the compliance status of the architectural design in terms of the prescriptive accessibility provisions of BCA 2019, as are contained within Part D3 and Clauses E3.6 and F2.4 of the code.

The table identifies compliance assessment outcomes into one of four (4) categories, as follows:

| | |
|-----------------------------|---|
| Complies | BCA design compliance is achieved |
| Does Not Comply | A BCA compliance departure requires rectification. Resolution options are provided. |
| N/A or Informational | Either not applicable or not directly relevant to the project. Detail provided for information purposes only. No action required. |
| Design Detail | A detailed commentary is provided within the report. Such instances should not be considered deficiencies but matters for consideration by the design team/assessment authority at relevant stages of design. |

BCA Interpretation Note(s):

- (i) Readily moveable furniture has been treated as indicative only. The person/s responsible for furnishing the building (parts) should ensure their furnishing layout/s do not cause AS1428.1 circulation deficiencies.

| BCA DEEMED-TO-SATISFY PROVISION | COMPLIES | DOES NOT COMPLY | N/A OR INFORMATIONAL | DESIGN DETAIL | COMMENTS |
|--|----------|-----------------|----------------------|---------------|---|
| SECTION D | | | | | |
| ACCESS & EGRESS | | | | | |
| PART D3 - ACCESS FOR PEOPLE WITH DISABILITIES | | | | | |
| <u>D3.1 - General building access requirements</u> Buildings and parts of buildings must be accessible as required by Table D3.1, as follows: <u>Class 5 / 9b</u> Access must be provided to and within all areas normally used by the occupants. | | X | | | Discussions held with the Architect confirmed the removal of Stair 2 from Zone B Ground floor plan and therefore it has not been considered as part of this access review. In addition to the above, discussions held with the Architect confirmed the cabinetry (sinks) to the Art/Aspect, GLA 4, 5 & 6 were currently under review to achieve compliance with the circulation spaces for doorways and are yet to be confirmed. Compliance to be determined at CC stage. The following requires to be addressed on amended plans; Zone A & B – Doorways <ul style="list-style-type: none"> New single doorways are notated to be recessed within 460mm thick walls. The Australian Standard is silent on the wall thickness with a |

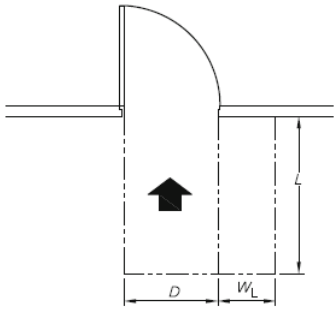
| BCA DEEMED-TO-SATISFY PROVISION | COMPLIES | DOES NOT COMPLY | NA OR INFORMATIONAL | DESIGN DETAIL | COMMENTS | | | | | | | | | | | | | | | | | | | | |
|---------------------------------|---------------|-----------------|---------------------|---------------|---|---------------|---------------|-----------------|-----------------|-----|------|---|-----|-----|------|---|-----|-----|------|---|-----|------|------|---|-----|
| | | | | | <p>swinging door located within. Discussions held with the Architect confirmed these doorways are under revision to ensure compliance can be achieved. Architect to confirm prior to CC stage. AED suggests that the wall opening be increased to account for the latch side clearances of where required by Clause 13.3 of 660mm (worst case scenario) of AS1428.1-2009. Alternatively, where the DtS provisions cannot be achieved discussions should be held with a suitably qualified access consultant to determine if a performance-based solution is applicable.</p> <p>Zone A – Ground floor</p> <ul style="list-style-type: none"> Doorway to office (adjoining student office & sick bay) maintains a latch side clearance of circa 150mm where 510mm is required when a frontal approach is taken, and the doorway opens away from the user in accordance with Clause 13.3 of AS1428.1-2009. Refer to figure 31(d) below. <div style="text-align: center;">  <table border="1" data-bbox="877 1321 1228 1456"> <thead> <tr> <th>Dimension D</th> <th>Dimension L</th> <th>Dimension W_H</th> <th>Dimension W_L</th> </tr> </thead> <tbody> <tr> <td>850</td> <td>1450</td> <td>0</td> <td>510</td> </tr> <tr> <td>900</td> <td>1450</td> <td>0</td> <td>510</td> </tr> <tr> <td>950</td> <td>1450</td> <td>0</td> <td>510</td> </tr> <tr> <td>1000</td> <td>1450</td> <td>0</td> <td>510</td> </tr> </tbody> </table> <p>(d) Front approach, door opens away from user</p> </div> <p>Zone B – Ground floor</p> <ul style="list-style-type: none"> Plans identifies doorways throughout the ground floor maintaining less than 850mm openings (circa 705mm). A doorway shall be 850mm when measured from the face of the opened door to the doorstop. Refer to figure 30 below for clear openings of doorways. All doors are to be reviewed to ensure 850mm opening exists. | Dimension D | Dimension L | Dimension W_H | Dimension W_L | 850 | 1450 | 0 | 510 | 900 | 1450 | 0 | 510 | 950 | 1450 | 0 | 510 | 1000 | 1450 | 0 | 510 |
| Dimension D | Dimension L | Dimension W_H | Dimension W_L | | | | | | | | | | | | | | | | | | | | | | |
| 850 | 1450 | 0 | 510 | | | | | | | | | | | | | | | | | | | | | | |
| 900 | 1450 | 0 | 510 | | | | | | | | | | | | | | | | | | | | | | |
| 950 | 1450 | 0 | 510 | | | | | | | | | | | | | | | | | | | | | | |
| 1000 | 1450 | 0 | 510 | | | | | | | | | | | | | | | | | | | | | | |

| BCA DEEMED-TO-SATISFY PROVISION | COMPLIES | DOES NOT COMPLY | NA OR INFORMATIONAL | X | DESIGN DETAIL | COMMENTS |
|---------------------------------|----------|-----------------|---------------------|---|---|---|
| | | | | | <p style="text-align: center;">DIMENSIONS IN MILLIMETRES</p> <p style="text-align: center;">FIGURE 30 CLEAR OPENING OF DOORWAYS</p> | <p>• Bi-fold doorways to ART room are not an acceptable doorway under AS1428.1-2009 and it is suggested that these doors are reviewed prior to CC stage.</p> <p><u>Design Requirements:</u></p> <p>Access is required to and throughout the building in accordance with AS1428.1-2009, to the following extent –</p> <ul style="list-style-type: none"> ▪ All parts. ▪ Carpark – see Clause D3.5. ▪ To storage areas. <p><u>Slip-resistant floor surface/s</u></p> <p>BCA 2019 does not directly specify slip-resistance classification(s) for all accessible paths of travel; however, we highlight the need under AS1428.1-2009 for all accessible paths of travel to have a slip-resistant surface. We recommend you should seek surface finish advice from an independent specialist slip safety consultant.</p> <p><u>Grates</u></p> <p>Where grates are provided, they shall not maintain circular/slotted openings greater than 13mm in diameter and slotted openings shall be oriented so that the long dimension is transverse to the dominant direction of travel.</p> <p>Spatial allowance in the current design indicates that compliance with AS1428.1-2009 is readily achievable.</p> <p>The following summary of AS1428.1-2009 requirements for accessways is provided to assist the project team.</p> |

| BCA DEEMED-TO-SATISFY PROVISION | COMPLIES | DOES NOT COMPLY | N/A OR INFORMATIONAL | DESIGN DETAIL | COMMENTS |
|---------------------------------|----------|-----------------|----------------------|---------------|----------|
|---------------------------------|----------|-----------------|----------------------|---------------|----------|

Summary of AS1428.1-2009 Requirements for accessways

Continuous accessible path of travel –

All paths of travel shall achieve unobstructed heights and widths in accordance with cl. 6 of AS 1428.1 – see diagram below for detail.

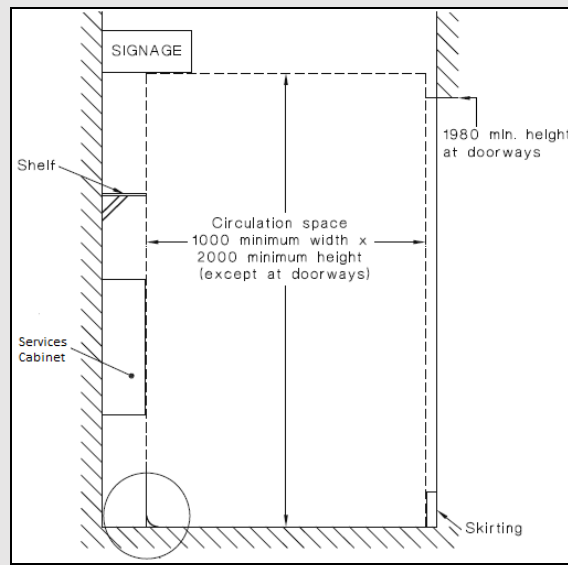

Doorways / Doors –

- (i) All doorways shall have a minimum luminance contrast of 30% between –
 - door leaf and door jamb;
 - door leaf and adjacent wall;
 - architrave and wall;
 - door leaf and architrave;
 - door jamb and adjacent wall.
- (ii) The minimum width of the area of luminance contrast shall be 50mm,
- (iii) Door hardware should be generally located between 900-1100mm from the floor and be of lever type with a clearance between the handle and the door face at the centre of the handle being not less than 35mm and not more than 45mm in accordance with AS1428.1-2009,
- (iv) Doors shall have a clear opening width of 850mm.
- (v) Door handles and related hardware shall be of the type that allows the door to be unlocked and opened with one hand. The handle shall be such that the hand of a person who cannot grip will not slip from the handle during the operation of the latch.
- (vi) 'D' type handles shall be provided on sliding doors.
- (vii) Any snibs shall have a lever handle of a minimum length of 45 mm from the centre of the spindle.
- (viii) For doors (other than fire doors and smoke doors) where a door closer is fitted, the force required at the door handle to operate the door shall not exceed the 20N,
- (ix) Where an outward opening door is not self-closing, a horizontal handrail or pull bar shall be fixed on the closing face of a side-hung door,
- (x) The location of controls for doors and gates above a level surface shall be provided as per Clause 13.5.3.
- (xi) Manual controls for power-operated doors shall be located no closer than 500 mm from an internal corner and between 1000 mm to 2000 mm from the hinged door leaf in any position or clear of a surface-mounted sliding door in the open position.

| BCA DEEMED-TO-SATISFY PROVISION | COMPLIES | DOES NOT COMPLY | N/A OR INFORMATIONAL | DESIGN DETAIL | COMMENTS |
|---------------------------------|----------|-----------------|----------------------|---------------|----------|
|---------------------------------|----------|-----------------|----------------------|---------------|----------|

- (xii) Push-button controls shall have a minimum dimension of 25 mm diameter and be proud of the surface and shall activate the door before the button becomes level with the surrounding surface.

Floor or ground surfaces on continuous accessible paths of travel and circulation spaces –

- (i) A continuous accessible path of travel and any circulation spaces shall have a slip-resistant surface. The texture of the surface shall be traversable by people who use a wheelchair and those with ambulant or sensory disability.
- (ii) Abutment of surfaces shall have a smooth transition. Design transition shall be 0mm, however, construction tolerances are as follows –
- 0 ±3mm vertical change in level – see Figure 1
 - 0 ±5mm change in level provided the edges have a beveled or rounded edge to reduce the likelihood of tripping – see Figure 2
 - Various tolerances for raked joint pavers – see Figure/s 3a - level surfaces, 3b - irregular surfaces & 3c - domed surfaces.

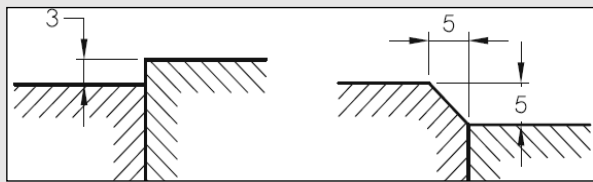

Figure 1

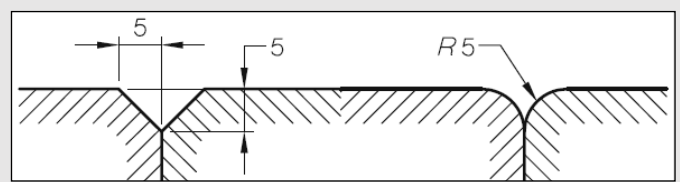

Figure 2

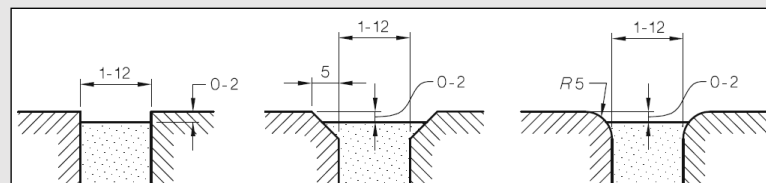

Figure 3a – For continuous paving units – level surfaces

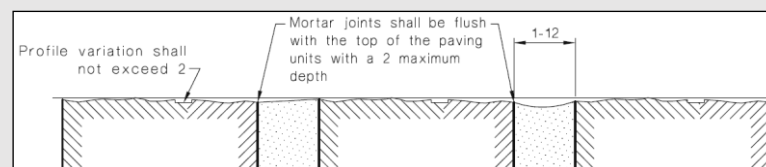

Figure 3b – For continuous paving units – irregular surfaces

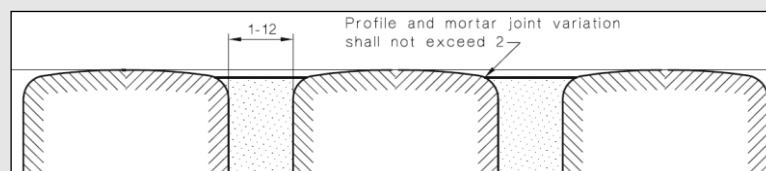
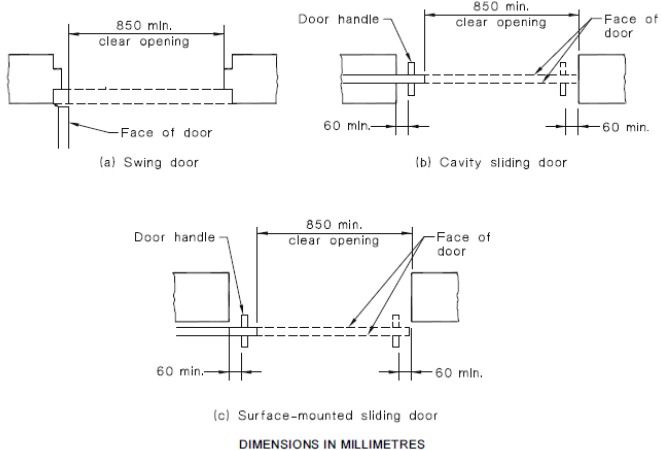

Figure 3c – For continuous paving units – domed surfaces

- (iii) Where carpets or any soft flexible materials are used on the ground or floor surface –
- The pile height or pile thickness, shall not exceed 11mm and the carpet backing thickness shall not exceed 4mm,
 - Exposed edges of floor covering shall be fastened to the floor surface and shall have a trim along the entire length of any exposed edge,
 - At the leading edges, carpet trims and any soft flexible materials shall have a vertical face no higher than 3mm or a rounded beveled edge no higher than 5mm or above that height a gradient of 1:8 up to a total maximum height of 10mm.

| BCA DEEMED-TO-SATISFY PROVISION | COMPLIES | DOES NOT COMPLY | N/A OR INFORMATIONAL | DESIGN DETAIL | COMMENTS |
|---|----------|-----------------|----------------------|---------------|---|
| <p>(iv) Matting recessed within an accessible path of travel –</p> <ul style="list-style-type: none"> ▪ Where of metal and bristle type construction or similar, its surface shall be no more than 3mm if vertical or 5mm if rounded or beveled, above or below the surrounding surface; and ▪ Where of a mat or carpet type material, shall have the fully compressed surface level with or above the surrounding surface with a level difference no greater than 3mm if vertical or 5mm if rounded or beveled. <p><u>Switches and Controls –</u></p> <p>(i) All new switches and controls, other than power points, shall be located not less than 900mm nor more than 1100mm above the finished floor and not less than 500mm from internal corners.</p> <p>(ii) Rocker action and toggle switches shall be provided an accordance with Clause 14.2 in accessible residential sole-occupancy units.</p> | | | | | |
| <p><u>D3.2 - Access to Buildings</u></p> <p>An accessway must be provided to a building required to be accessible:</p> <ul style="list-style-type: none"> ▪ From the main points of pedestrian entry at the allotment boundary; and ▪ From another accessible building connected by a pedestrian link; and ▪ From any required accessible carparking space on the allotment. <p>An accessway must be provided through the principal pedestrian entrance, and:</p> <ul style="list-style-type: none"> ▪ through not less than 50% of all pedestrian entrances including the principal pedestrian entrance; and ▪ in a building with a floor area more than 500m², a pedestrian entrance which is not accessible must not be located more than 50m from an accessible pedestrian entrance. <p>Doorway on an accessway having multiple leaves must have a clear opening width of not less than 850mm for a single leaf.</p> | X | | | | <p>Discussions held with the Architect confirmed an accessway is to be provided from Fitzgerald Avenue along the eastern side of Zone B Building and will link up to the hall and the new concrete pathway, therefore connecting all buildings onsite. Additional details to be provided at CC stage.</p> <p>The following requires to be addressed on amended plans;</p> <p><u>Access to buildings</u></p> <ul style="list-style-type: none"> • Site inspection carried out on 3rd September 2019 identified four (4) access points at the lot boundaries. Plans only identify one point of entry to be accessible where two (2) accessways are to be provided in accordance with D3.2. AED notes that the secondary access will be provided from the allotment boundary on Fitzgerald Avenue, however the existing concrete path located on Council's land will not achieve compliance with the requirements of AS1428.1-2009. This matter should be raised with Council have the path replaced/realigned. • Plans indicate an accessway to Zone B building via an internal lift of Zone A building. AED notes that an accessway has been provided, however in the event that access via the lift cannot be accessed then a accessway to Zone B building is not attainable. Client to provide a written statement confirming that access to the lift is to be provided at all times when the buildings are in use. This statement should form part of the building Plan of Management to avoid any future conflicts. • Walkway connecting buildings from Zone A to Zone B do not identify a kerb or kerb rail and handrail or a wall not less than 450mm in height to both sides of where one of these options are required in accordance with Clause 10.2 of AS1428.1-2009. |

| BCA DEEMED-TO-SATISFY PROVISION | COMPLIES | DOES NOT COMPLY | NA OR INFORMATIONAL | DESIGN DETAIL | COMMENTS |
|---|----------|-----------------|---------------------|---------------|--|
| | | | | | <p>Zone B – Ground floor</p> <p>Double doors</p> <ul style="list-style-type: none"> Plans notate double doors (existing and proposed) with a single leaf door maintain a clear opening of 850mm (circa 635mm – worst case scenario). Double doors on a continuous accessible path of travel must maintain one leaf (active leaf) width of 850mm in accordance with Clause 13.2 of AS1428.1-2009. Refer to figure 30 below for clear openings of doorways.  <p>Design Requirements:</p> <p>Main entry point are indicated as accessible, as required.</p> <p>Double doors to be provided with 850mm clear opening for a single leaf.</p> <p>Otherwise, compliance is readily achievable.</p> <p>We refer to the AS1428.1-2009 summary at Clause D3.1 to assist the design team with detailed design and/or construction.</p> |
| <p>D3.3 - Parts of buildings to be accessible</p> <p>In a building required to be accessible:</p> <ul style="list-style-type: none"> every ramp & walkway (except fire-isolated) must comply with Clause 10 of AS1428.1-2009; | | | | <p>X</p> | <p>Design Requirements:</p> <p>All stairs and ramps (other than required fire-isolated stairs and ramps) are to be design detailed to comply with the relevant requirements of Clause 10 and 11 of AS1428.1-2009.</p> <p>Suitable passing and turning spaces are to be provided in the building to comply with this clause and AS1428.1-2009.</p> |

| BCA DEEMED-TO-SATISFY PROVISION | COMPLIES | DOES NOT COMPLY | NA OR INFORMATIONAL | DESIGN DETAIL | COMMENTS |
|--|----------|-----------------|---------------------|---------------|--|
| <ul style="list-style-type: none"> ▪ every stairway (<i>except fire-isolated</i>) must comply with Clause 11 of AS1428.1-2009; ▪ All fire-isolated stairways are required to comply with Clause 11.1(f) and (g) of AS 1428.1-2009. ▪ accessways must have passing spaces complying with AS1428.1 at max 20m intervals where a direct line of sight is not available; and ▪ turning spaces complying with AS1428.1 within 2m of the end of accessways where it is not possible to continue travelling along the accessway, and at max. 20m intervals along the accessway. ▪ Ramp or passenger lift access need not be provided to serve a storey or level other than the entrance storey in a Class 5, 6,7b or 8 building containing not more than 3 storeys and with a floor area for each storey of not more than 200m². ▪ the carpet pile height or pile thickness dimension, carpet backing thickness dimension and their combined dimension shall be 11mm, 4mm & 15mm respectively. | | | | | <p>The following Clause 10, 11 & 12 summary of AS1428.1-2009 is provided to assist the project team.</p> |

Summary of AS1428.1-2009; Clause 10 & 11 Requirements (Ramps & Stairs)

Clause 10.2 – Walkways

Walkways shall comply with the following:

- The floor or ground surface abutting the sides of the walkway shall provide a firm and level surface of a different material to that of the walkway at the same level of the walkway, follow the grade of the walkway and extend horizontally for a minimum of 600 mm unless one of the following is provided:
 - Kerb in accordance with Figure 18.
 - Kerb rail and handrail in accordance with Figure 19.
 - A wall not less than 450 mm in height.
- Landings at top and bottom and at:
 - 25m intervals or less for 1:33,
 - 15m intervals or less for 1:20,
- For walkways shallower than 1 in 33, no landings are required.

Clause 10.3 – Ramps

| BCA DEEMED-TO-SATISFY PROVISION | COMPLIES | DOES NOT COMPLY | NA OR INFORMATIONAL | DESIGN DETAIL | COMMENTS |
|--|----------|-----------------|---------------------|---------------|----------|
| Ramps shall comply with the following: | | | | | |
| <ul style="list-style-type: none"> ▪ Max 1:14 gradient for ramps exceeding 1.9m, ▪ Gradient constant throughout with max. 3% tolerance and max 1:14 gradient, ▪ Landings at top and bottom and at: <ul style="list-style-type: none"> - 9m intervals or less for 1:14, - 15m intervals or less for 1:20, ▪ Change in direction to have 90° angle of approach as per Figure 13, ▪ Handrails on each side as per Clause 12, ▪ Set back min. 900mm from boundary, ▪ Intersections at internal corridors to be set back min. 0.4m, ▪ Handrails to extend min. 300mm horizontally past transition point at top and bottom, except where inner handrail is continuous at intermediate landings, ▪ Kerbs and kerb rails on both sides at min. height of 65mm, not be between 75mm and 150mm high and have no gaps or slots greater than 20mm within the range of 75mm to 150mm, ▪ Kerbs and kerb rails to be located so that ramp-side face is either flush or no greater than 100mm away from handrail (Figure 19), min. 150mm high if handrails has vertical posts (Figure 19 a, b, c), and be min. 200mm between 65mm-75mm kerb to support posts (Figure 19 d). | | | | | |
| <u>Clause 10.5 - Threshold ramps</u> | | | | | |
| <ul style="list-style-type: none"> ▪ Threshold ramps at doorways to have a max. rise of 35mm, max length of 280mm, max gradient of 1:8 and be located within 20mm of the door leaf. ▪ Edges of the threshold ramp shall be tapered or splayed at max 45° if not abutting a wall. | | | | | |
| <u>Clause 10.6 - Step ramps</u> | | | | | |
| <ul style="list-style-type: none"> ▪ Step ramps shall have max. rise of 190mm, max. length of 1.9m, max. gradient of 1:10. ▪ Edges of the step ramp to have 45° splay where there is pedestrian traffic or otherwise be protected by suitable barrier such as a min. 450mm wall or kerb / kerb rail with open balustrade. ▪ Step ramps to have slip-resistant surfaces. | | | | | |
| <u>Clause 10.8 - Landings</u> | | | | | |
| Landings for walkways (up to 1:33) and ramps shall comply with one of the following: | | | | | |
| <ul style="list-style-type: none"> ▪ min. 1.2m if no change in direction as per Figure 25(A), ▪ min. 1.5m where change in direction not exceeding 90° internal corner to be truncated for min. 500mm in both directions as per Figure 25(B), ▪ 180° turn, landing as per Figure 25(C). ▪ Landings for step ramps shall be min. 1.2m in length as per Figure 22(A) and (B). Where a change in direction, the length of the step ramp landing to be min. 1.5m as per Figure 22(A). At doorways, landings as per Clause 13.3 for circulation spaces at doorways shown in Figure 25(D). ▪ Landings at kerb ramps shall be min. 1.2m in length, or 1.5m X 2.0m at 'T' junctions. Where a single change in direction is required, landings to be min. 1.5m X 1.5m. | | | | | |
| <u>Clause 11.1 - Stair construction</u> | | | | | |
| Stairs to be constructed as follows: | | | | | |
| <ul style="list-style-type: none"> ▪ Set back min. 0.9m from boundary, ▪ Where intersection is at an internal corridor, the stair to be set back as per Figure 26(A), | | | | | |

| BCA DEEMED-TO-SATISFY PROVISION | COMPLIES | DOES NOT COMPLY | N/A OR INFORMATIONAL | DESIGN DETAIL | COMMENTS |
|---|----------|-----------------|----------------------|---------------|---|
| <ul style="list-style-type: none"> ▪ Have opaque risers, ▪ Nosings shall not project beyond the face of the riser and the riser may be vertical of 25mm backwards splay, ▪ Nosing profiles to have a sharp intersection, be rounded up to 5mm radius or be chamfered up to 5mm x 5mm, ▪ 50mm – 75mm strip to full length of nosing, set back a max. 15mm from the front of the nosing, with a 30% min. luminance contrast. If not set back, luminance contrast to extend down the riser by max 10mm. ▪ TGSIs installed as per AS1428.4.1. <p><u>Clause 11.2 - Stairway handrails</u></p> <p>Handrails to be continuous throughout the stair flight and around landings and have no obstructions 0.6m above, and as follows:</p> <ul style="list-style-type: none"> ▪ Design & construction as per Clause 12, ▪ Installed both sides, ▪ No vertical sections and shall follow angle of the stairway nosings, ▪ Extend at bottom of stairs one stair tread depth and min. 300mm horizontally, (300mm extension not required if handrail is continuous, ▪ Dimensions of heights of handrails taken vertically from the nosing or landing to the top of the handrail. <p><u>Clause 12 - Handrails</u></p> <p>Design and construction to comply with:</p> <ul style="list-style-type: none"> ▪ Handrails and balustrades shall not encroach into required circulation, ▪ Circular or elliptical cross-section, not less than 30mm or more than 50mm for more than 270°. Elliptical handrails to have greater horizontal dimensions, ▪ Exposed edges or corners have min. radius of 5mm, ▪ Top of handrail to be between 865mm and 1.0m above nosing or landing, ▪ Height to be constant throughout, ▪ If balustrade is required at a height greater than the handrail, both shall be provided, ▪ Handrails to be securely fixed and rigid with ends turned through a total of 180°, or to the ground, or returned fully to end post or wall face (Figures 26 C and D), ▪ Min. 50mm clearance to adjacent wall or other obstruction, for a height of 600mm, ▪ Handrails to have no obstructions to the passage of a hand along the rail, ▪ Inside handrail at landings to always be continuous as per Figure 28(a). | | | | | |
| <p><u>D3.4 - Exemptions</u></p> <p>An area where access would be inappropriate because of the particular purpose for which the area is used, or would pose a health or safety risk for people with a disability; is not required to be accessible.</p> | | | X | | <p>Exemptions are to be reviewed on a case by case basis and when detailed design is achieved. Although, we do highlight that the following parts of the building have been offered access exemption (not exhaustive):</p> <ul style="list-style-type: none"> ▪ Electrical rooms. ▪ Plant & equipment room(s). ▪ Service rooms. ▪ Doorway connecting Library to administration building |
| <p><u>D3.5 - Accessible carparking</u></p> <p>Accessible carparking spaces complying with AS2890.6-2009 must be provided in accordance with Table D3.5 in a Class 7a building required to</p> | | | X | | <p>Not applicable – there are no onsite carparking. The site is dependent upon street parking.</p> |

| BCA DEEMED-TO-SATISFY PROVISION | COMPLIES | DOES NOT COMPLY | NA OR INFORMATIONAL | DESIGN DETAIL | COMMENTS |
|---|----------|-----------------|---------------------|---------------|--|
| be accessible and on the same allotment as a building required to be accessible. | | | | | |
| <p><u>D3.6- Signage</u></p> <p>Accessible buildings must have signage to comply with AS1428.1-2009 and as follows –</p> <ul style="list-style-type: none"> ▪ braille and tactile signage incorporating the international symbol of access or deafness, must identify each sanitary facility and space with hearing augmentation system; and ▪ identify each door required by Clause E4.5 to be provided with an exit sign and state “Exit” and “Level” followed by the floor number; ▪ signage incorporating the international symbol of access or deafness, must be provided within a room containing a hearing augmentation system identifying the hearing augmentation type, area covered and location of receivers; ▪ signage in accordance with AS1428.1 must be provided for accessible unisex sanitary facilities to identify left or right handed use; ▪ signage to ambulant accessible facility must be on the door of the facility; ▪ directional signage where a pedestrian entrance is not accessible, ▪ directional signage where a bank of sanitary facilities are not provided with an accessible sanitary facility. | | | | X | <p>Signage shall be installed in this project as necessary, but shall include as a minimum:</p> <ul style="list-style-type: none"> ▪ identify each door required by Clause E4.5 to be provided with an exit sign and state “Exit” and “Level” followed by the floor number, as includes braille and tactile signage; ▪ signage in accordance with AS1428.1 must be provided for accessible unisex & ambulant sanitary facilities to identify left or right-handed use; ▪ directional signage where a bank of sanitary facilities are not provided with an accessible & ambulant sanitary facilities. <p>All signage is to be design detailed to comply with the relevant requirements of Specification D3.6. In this regard, the following Specification D3.6 summary is provided to assist the project team.</p> |

Summary of Specification D3.6: Braille and tactile signs

Part 2 – Location of braille and tactile signs

Signage must be designed and installed as follows:

- Braille and tactile components located not less than 1.2m or greater than 1.6m;
- Single line signs to have tactile characters not less than 1.25m or greater than 1.35m;

| BCA DEEMED-TO-SATISFY PROVISION | COMPLIES | DOES NOT COMPLY | NA OR INFORMATIONAL | DESIGN DETAIL | COMMENTS |
|--|----------|-----------------|---------------------|---------------|--|
| <ul style="list-style-type: none"> Signs identifying room features or facilities located on wall on the latch side of the door with edge of sign 50mm to 300mm from the architrave (or on the door itself if not possible to have adjacent). Signs identifying a door required by E4.5 to be provided with an exit sign, must be located on the side that faces a person seeking egress, and on the wall on the latch side of the door with the leading edge of the sign located between 50mm and 300mm from the architrave (or on the door itself if not possible adjacent). <p><u>Part 3 – Braille and tactile sign specification</u></p> <ul style="list-style-type: none"> Tactile characters to be raised or embossed to a height between 1mm and 1.5mm; Sentence case must be used, with 15mm to 50mm high characters for capitals and 50% high for the lower case; Tactile characters, symbols and the entire sign / frame to have rounded edges; The entire sign including characters, background, negative space or fill of signs to be matt or low gloss finish; Min. letter spacing to be 2mm; Min. word spacing to be 10mm; Thickness of letter strokes between 2mm and 7mm and of Arial typeface; Tactile text to be left justified (excluding single words). <p><u>Part 4 – Luminance contrast</u></p> <ul style="list-style-type: none"> Background, negative space and fill to be min. 30% luminance contrast to the mounted surface, Tactile characters icons & symbols to be min 30% luminance contrast to the background or mount surface, Luminance contrasts must be met under the lighting conditions of its surrounds. <p><u>Part 5 – Lighting</u></p> <p>Braille and tactile signs must be illuminated to ensure luminance contrast requirements are met at all times during which the sign is required to be read.</p> <p><u>Part 6 – Braille</u></p> <ul style="list-style-type: none"> Grade 1 braille (uncontracted) as per Australian Braille Authority, Raised and domed, and left justified, Located 8mm below bottom line of text, Solid arrow, if arrow provided, On signs with multiple lines, semicircular braille locator at the left margin must be horizontally aligned with the first line of braille text. | | | | | |
| <p><u>D3.7 - Hearing augmentation</u></p> <p>Hearing augmentation system must be provided where an inbuilt amplification system (other than emergency warning) is installed:</p> <ul style="list-style-type: none"> In a room in a Class 9b building; or Meeting room, conference room, auditorium, or room for judicatory purposes; or At any ticket office, tellers booth, reception area or the like, where the public is screened from the service provider. | | | X | | Architect to advise if the building will be fitted with a hearing augmentation system. |



| BCA DEEMED-TO-SATISFY PROVISION | COMPLIES | DOES NOT COMPLY | NA OR INFORMATIONAL | DESIGN DETAIL | COMMENTS |
|--|----------|-----------------|---------------------|---------------|---|
| <p>If provided in the form of an induction loop, it must cover no less than 80% of the floor of the room served.</p> <p>If in the form of receivers, it must cover no less than 95% of the floor of the room served with a minimum of two (2) in any case, but depending on number of people accommodated.</p> <p>Any screen or scoreboard in a Class 9b capable of displaying public announcements must be capable of supplementing any public address system, other than one used for emergency warning purposes only.</p> | | | | | |
| <p><u>D3.8 - Tactile ground surface indicators (TGSi)</u></p> <p>Accessible buildings must have TGSi's complying with Sections 1 & 2 of AS/NZS1428.4.1-2009 to warn blind or vision impaired people of approaching stairways (other than fire-isolated), escalators, ramps (other than fire-isolated, step or kerb ramp), any overhead obstruction less than 2m above floor level and an accessway meeting a vehicular way adjacent to any pedestrian entrance to a building.</p> | | | | X | <p>TGSi's are to be provided to –</p> <ul style="list-style-type: none"> ▪ any overhead obstruction less than 2m above floor level. ▪ top and bottom of all stairways and ramps (except fire-isolated stairways). ▪ where an accessway meets a vehicular way adjacent to any pedestrian entrance to a building |
| <p><u>D3.9 - Wheelchair seating spaces in Class 9b assembly buildings</u></p> <p>Where fixed seating is provided in a Class 9b assembly building, wheelchair seating spaces complying with AS 1428.1 must be provided in accordance with Table D3.9.</p> | | | | X | Not applicable |
| <p><u>D3.11 - Ramps</u></p> <p>On an accessway; a series of connected ramps must not have a combined vertical rise of more than 3.6 m; and a landing for a step ramp must not overlap a landing for another step ramp or ramp.</p> | | | | X | Not applicable |





| BCA DEEMED-TO-SATISFY PROVISION | COMPLIES | DOES NOT COMPLY | NA OR INFORMATIONAL | DESIGN DETAIL | COMMENTS |
|--|----------|-----------------|---------------------|---------------|--|
| <p><u>D3.12 - Glazing on an accessway</u></p> <p>Where there is no chair rail, handrail or transom, all frameless or fully glazed doors, sidelights, including any glazing capable of being mistaken for a doorway or opening, shall be clearly marked for their full width with a solid contrasting line.</p> <p>The contrasting line shall be not less than 75mm wide and shall extend across the full width the glazing panel. The lower edge of the contrasting line shall be located between 900mm and 1000mm above the plane of the finished floor level.</p> <p>Any contrasting line on the glazing shall provide a minimum of 30% luminance contrast when viewed against the floor surface or surfaces within 2m of the glazing on the opposite side.</p> | | | | X | Any such glazing on an accessway must be clearly marked in accordance with Clause 6.6 of AS 1428.1-2009. |

SECTION E

SERVICES AND EQUIPMENT

PART E3

LIFT INSTALLATIONS

| | | | | | |
|---|--|--|--|---|---|
| <p><u>E3.6 - Passenger lifts</u></p> <p>Every passenger lift must:</p> <ul style="list-style-type: none"> ▪ be one of the types identified in Table E3.6a, subject to the limitations on use specified in the Table; and ▪ have accessible features in accordance with Table E3.6b; and ▪ not rely on a constant pressure device for its operation if the lift car is fully enclosed. | | | | X | <p>The proposed passenger lifts (x1) shall have the following features –</p> <ul style="list-style-type: none"> (i) Handrail complying with the mandatory handrail provisions of AS1735.12, (ii) Lift floor dimensions not less than 1,400mm x 1,600mm as the lifts vertical travel are greater than 12m, (iii) Minimum clear door opening complying with AS1735.12, (iv) Passenger protection system complying with AS1735.12, (v) Lift landing doors at the upper landing, (vi) Lift car and landing control buttons complying with AS1735.12, (vii) Lighting in accordance with AS1735.12, (viii) Lifts serving more than 2 Levels – |
|---|--|--|--|---|---|





| BCA DEEMED-TO-SATISFY PROVISION | COMPLIES | DOES NOT COMPLY | NA OR INFORMATIONAL | DESIGN DETAIL | COMMENTS |
|---------------------------------|----------|-----------------|---------------------|---------------|---|
| | | | | | <ul style="list-style-type: none"> ▪ Automatic audible information within the lift car to indicate the level each time the lift car stops; ▪ audible and visual indication at each lift landing to indicate the arrival of the lift car; ▪ audible information and audible indication is to be provided in a range of between 20-80dB(A) at a maximum frequency of 1500Hz; <p>(ix) Emergency hands-free communication, including a button that alerts a call centre of a problem and a light to signal that the call has been received.</p> <p>The lifts shall be detail designed to ensure compliance with the above and AS1428.1.</p> <p>A design compliance certificate should be obtained from the lift designer to confirm compliance with the relevant provisions of the BCA and Australian Standards.</p> <p>Consideration should be given to lift control buttons and the like (no less than 500mm from an internal corner).</p> |

SECTION F

HEALTH AND AMENITY

PART F2

SANITARY AND OTHER FACILITIES

| | | | | | |
|---|---|--|--|---|---|
| <p><u>F2.4 - Accessible sanitary facilities</u></p> <p>In a building required to be accessible:</p> <ul style="list-style-type: none"> ▪ Accessible unisex sanitary compartments must be provided as per Table F2.4(a), ▪ Accessible unisex showers must be provided as per Table F2.4(b), ▪ At each bank of toilets where there is one or more toilets in addition to an accessible unisex sanitary compartment at that bank of toilets, a sanitary compartment suitable for a person with an ambulant disability in accordance with AS 1428.1 must be provided for use by males and females. ▪ An accessible unisex sanitary compartment must contain a closet pan, washbasin, shelf or bench top and adequate disposal of sanitary towels. | X | | | X | <p>The following requires to be addressed on amended plans;</p> <p><u>Zone A – Ground floor</u></p> <ul style="list-style-type: none"> • At a bank of toilets of toilets where there is one or more toilets in addition to an <i>accessible unisex sanitary compartment</i> at that bank of toilets, a <i>sanitary compartment</i> suitable for a person with an ambulant disability in accordance with AS 1428.1 must be provided for use by males and females. Zone A identifies two toilets to be ambulant, however grabrails have not been identified where required by Clause 16 of AS1428.1-2009. Details to be confirmed at CC stage. <p><u>Design Requirements:</u></p> <p>Fixtures and fittings within the accessible sanitary facilities shall comply with the requirements of Part 15 of</p> |
|---|---|--|--|---|---|



| BCA DEEMED-TO-SATISFY PROVISION | COMPLIES | DOES NOT COMPLY | NA OR INFORMATIONAL | DESIGN DETAIL | COMMENTS |
|---|----------|-----------------|---------------------|---------------|---|
| <ul style="list-style-type: none"> ▪ Circulation spaces, fixtures and fittings of all accessible sanitary facilities must comply with AS1428.1. ▪ Where two or more of each type of accessible unisex sanitary facility are provided, the number of left and right handed mirror image facilities must be provided as evenly as possible. ▪ An accessible unisex facility must be located so that it can be entered without crossing an area reserved for one sex. | | | | | <p>AS1428.1-2009. Layout should make allowance for a 2,300mm x 2,630mm compartment.</p> <p>A sanitary compartment suitable for a person with an ambulant disability in accordance with Part 16 of AS1428.1 must be provided for use by males and females.</p> <p>Compliance is readily achievable.</p> <p>The following summary of requirements for accessible sanitary facilities is provided to assist the project team during detailed design &/or construction.</p> |

Summary of AS1428.1-2009 requirements for Accessible & Ambulant Sanitary Facilities

Water Taps – Must have:

- Taps shall have lever handles, sensor plates or other similar control,
- Lever handles to be min. 50mm clear from adjacent surface,
- Where hot water is provided, the water to be delivered through the mixing spout.

WC pan clearances

- WC pan clearance including set-out, seat height and seat width as per Figure 38 of AS1428.1.

Seat – As follows:

- full round type with minimal contours,
- be securely fixed when in use,
- seat fixings that create lateral stability,
- load rated to 150kgs,
- min. luminance contrast of 30%.

Backrest – As follows:

- be capable of withstanding 1100 N,
- height to the lower edge of backrest to the top of the WC pan of 120mm to 150mm,
- vertical height of 150mm-200mm and a width of 350mm and 400mm,
- front edge of the centre of the backrest to be at an angle of 95° to 100°.

Flushing control

- Flushing controls shall be user activated, either hand operated or automatic. Hand-operated controls to comply with Figure 40, or on the centre-line of the toilet within the vertical limit zone. Controls within this zone shall not be within the area required for grabrails.
- Controls shall be proud of the surface and activate the flush before being level with the surrounding surface.

Toilet paper dispenser

- Toilet paper dispenser to be located within zone specified in Figure 41. Dispenser shall not encroach on required grabrail clearances.

| BCA DEEMED-TO-SATISFY PROVISION | COMPLIES | DOES NOT COMPLY | NA OR INFORMATIONAL | DESIGN DETAIL | COMMENTS |
|---------------------------------|----------|-----------------|---------------------|---------------|----------|
|---------------------------------|----------|-----------------|---------------------|---------------|----------|

Grabrails

- Concealed, high level cisterns or flush valves require a continuous grabrail across the rear wall and the side wall closest to the pan as per Figure 42.
- Low-level non-concealed cistern or flush valves require the grabrail to terminate each side of the cistern as per Figure 42.

Circulation space – Shall be as per Figure 43 of AS1428.1-2009, except for the following intrusions:

- Toilet paper dispenser,
- Grabrails,
- Washbasins with 100mm intrusion,
- Hand dryers and towel dispensers,
- Soap dispensers,
- Shelves,
- Wall cabinets with 150mm intrusion, mounted between 0.9m and 1.25m,
- Clothes hanging devices,
- Portable sanitary disposal units (Figure 43),
- Other wall mounted fixtures with 150mm intrusion, mounted between 0.9m and 1.25m.
- The overlapping of circulation space shall be in accordance with Clause 15.6.

Baby change tables

- Where installed, baby change tables shall not encroach into the required circulation space when in the folded position and have a max height of 820mm with clearance underneath of min. 720mm when open.

WC doors

- To be either hinged or sliding,
- Outward-opening doors shall have a mechanism to hold in the closed position without the use of a latch,
- Doors provided with an in-use indicator and a bolt or catch. If fitted with a snib, the snib handle is to be min. length of 45mm from the centre of the spindle.
- Latch mechanism are to be openable from the outside in the case of an emergency.
- Force required as per Clause 13.5.2(e),
- Door handles and hardware as per Clause 13.5.

Washbasins for unisex accessible sanitary facilities

- A hand-washing facility shall be provided inside the toilet cubicle

Washbasins – As follows:

- Shall be located inside the cubicle,
- Washbasin outside pan circulation,
- Water taps as per Clause 15.2.1,
- Exposed hot water supply pipes to be insulated or located so as not a hazard,
- Projection of washbasins from wall and taps, bowl and drain outlet as per Figures 44 (A) and (B),
- Water supply pipes and waste outlets not to encroach on required clear space under basin.
- Each washbasin fixture to have unobstructed circulation space as per Figure 46, or Figure 45 for SOU's.



| BCA DEEMED-TO-SATISFY PROVISION | COMPLIES | DOES NOT COMPLY | NA OR INFORMATIONAL | DESIGN DETAIL | COMMENTS |
|---|----------|-----------------|---------------------|---------------|----------|
| <p><u>Mirrors</u></p> <ul style="list-style-type: none"> ▪ Mirror to be located above or adjacent to washbasin. ▪ Where provided, a vertical mirror with a reflective surface not less than 350mm wide to extend from a height not less than 0.6m to not more than 1.85m. ▪ In an accessible residential unit, the mirror to be centred over the washbasin. | | | | | |
| <p><u>Shelves</u> – To be provided adjacent to washbasin, as follows:</p> <ul style="list-style-type: none"> ▪ A vanity top at a height of 800mm-830mm and min. width of 1200mm and depth of 300mm-400mm without encroaching circulation space, ▪ A separate fixture, within any circulation spaces at a height of 0.9m-1.0m, and external to all circulation space 0.79m-1.0m. | | | | | |
| <p><u>Soap dispensers, towel dispenser and similar fittings</u></p> <ul style="list-style-type: none"> ▪ Soap and towel dispensers and hand dryers shall be operable by one hand and installed so the operative component or outlet between 0.9m and 1.1m and no closer than 0.5m from an internal corner. | | | | | |
| <p><u>Clothes-hanging devices</u></p> <ul style="list-style-type: none"> ▪ A clothes-hanging device shall be installed 1.2m to 1.35m high and not less than 0.5m from an internal corner. | | | | | |
| <p><u>Sanitary disposal unit</u></p> <ul style="list-style-type: none"> ▪ Where provided, sanitary disposal units to be as per Figure 43 for portable units or 0.5m from the pan for recessed units. | | | | | |
| <p><u>Switches and general purpose outlets</u></p> <ul style="list-style-type: none"> ▪ Where provided near the washbasin, switches and GPOs to be located as per Clause 14 and as close to the shelf as possible. | | | | | |
| <p><u>Showers</u></p> <ul style="list-style-type: none"> ▪ Shower recesses and circulation space to a height not less than 0.9m as per Figure 47. Grabrails, shower hose fittings, taps, soap holder, shelf and seat are the only fixtures permitted in these spaces. | | | | | |
| <p><u>Circulation spaces in accessible sanitary facilities</u></p> <ul style="list-style-type: none"> ▪ Circulation spaces in accessible sanitary facilities shall be in accordance with Clause 15.2.8 and Figures 43-47 and 50. ▪ Circulation spaces, including door circulation space, may be overlapped. ▪ Fixtures shall not encroach circulation space except: <ol style="list-style-type: none"> a. Washbasin in WC circulation as per Figure 43, b. Washbasin in shower circulation as per Figure 50, c. Washbasin in door circulation as per Figure 51(A) and 51(B). ▪ Clearances beneath washbasin as per Clause 15.3. | | | | | |
| <p><u>Summary of AS1428.1-2009 requirements for Ambulant Sanitary Facilities</u></p> | | | | | |

| BCA DEEMED-TO-SATISFY PROVISION | COMPLIES | DOES NOT COMPLY | NA OR INFORMATIONAL | DESIGN DETAIL | COMMENTS |
|---|----------|-----------------|---------------------|---------------|----------|
| <u>General</u> | | | | | |
| <ul style="list-style-type: none"> Ambulant sanitary facilities shall be in accordance with Figures 53(A) and 53(B). | | | | | |
| <u>Grabrails</u> | | | | | |
| <ul style="list-style-type: none"> Grabrails shall be installed in accordance with Clause 17 and Figure 53(A). | | | | | |
| <u>Doors</u> | | | | | |
| <ul style="list-style-type: none"> Doors to sanitary compartments for people with ambulant disabilities shall have openings with a minimum clear width of 700 mm, and shall comply with Figure 53(B). Doors shall be provided with an in-use indicator and a bolt or catch. Where a snib catch is used, the snib handle shall have a minimum length of 45 mm from the centre of the spindle. In an emergency, the latch mechanism shall be openable from the outside. | | | | | |
| <u>Coat hook</u> | | | | | |
| <ul style="list-style-type: none"> A coat hook shall be provided within the sanitary compartment and at a height between 1350 mm to 1500 mm from the floor. | | | | | |

3.0 CONCLUSION

This report identifies the compliance status of the design with the relevant accessibility related Deemed-to-Satisfy (DtS) requirements of the Building Code of Australia (BCA) 2019.

The outcome of the report highlights that the current design contains some non-compliances with the DtS provisions of the BCA, however, such can be readily resolved by minor design changes or BCA Alternative Solution(s), as nominated at Part 2.0 of this report.

| | |
|--|--|
| <p>Prepared by:</p>  Clint Mills Building Consultant For AED | <p>Checked by:</p>  Trenton Jones Director For AED |
|--|--|